

## ANELLI DI CENTRAGGIO CENTERING RINGS

**MATERIALE:** C45  
**FINITURA:** Torniti  
**TOLLERANZA "L":**  $\pm 0,05$

**MATERIAL:** C45  
**FINISHING:** Turned  
**TOLERANCE "L":**  $\pm 0,05$

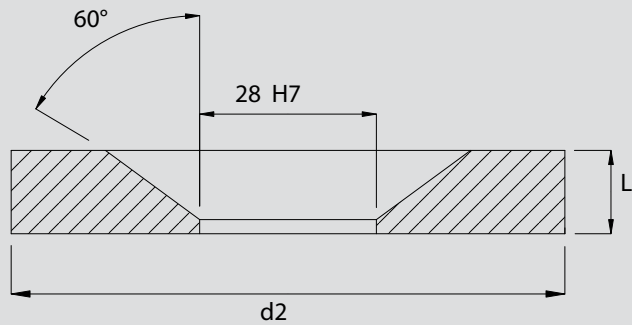

	d2	60	70	80	90	100	125	150	160	175	200
<b>PREZZI €</b>	L10	5,50	5,70	5,90	6,20	7,20	8,90	12,00	13,50	14,50	16,00
	L20	-	-	8,90	-	10,60	13,00	17,20	21,50	24,00	27,50

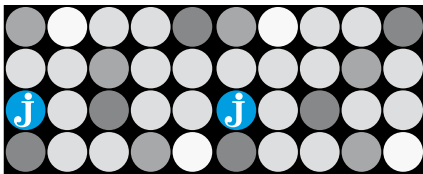

## BUSSOLE DI INIEZIONE INJECTION BUSHES

**MATERIALE:** 38 NCD4  
**FINITURA:**  
foro conico 5% alesato e lappato  
**TOLLERANZA:** d ISA h6

**MATERIAL:** 38 NCD4  
**FINISHING:**  
5% bored and lapped conical hole  
all bushes are fully ground on centres  
**TOLERANCE:** d ISA h6

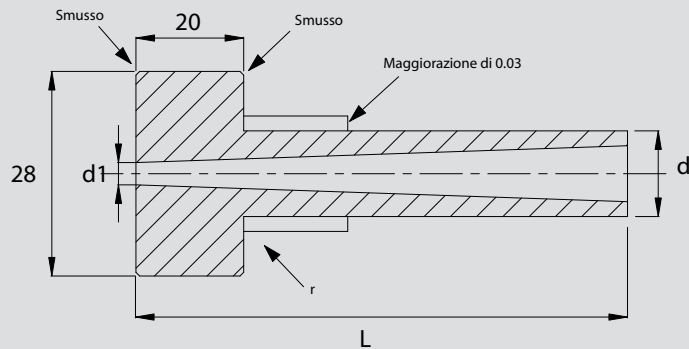

TUTTE LE BUSSOLE SONO INTERAMENTE RETTIFICATE SUI CENTRI • ALL THE ITEMS ARE FINISHED WITH CENTER GRINDING MACHINE

		LUNGHEZZA / length							
		50	65	75	85	95	105	115	125
d	d1	PREZZI €							
14	3	14,20	15,10	16,40	17,00	18,00	21,80	22,60	27,25
18	3	14,20	15,10	16,40	17,00	18,00	21,80	22,60	27,25
14	4	14,20	15,10	16,40	17,00	18,00	21,80	22,60	27,25
18	4	14,20	15,10	16,40	17,00	18,00	21,80	22,60	27,50
<b>TEMPERATE / HARDENED</b>	14	15,80	17,20	18,50	19,10	20,00	23,90	25,00	30,00
	18	15,80	17,20	18,50	19,10	20,00	23,90	25,00	30,00
	14	15,80	17,20	18,50	19,10	20,00	23,90	25,00	30,00
	18	15,80	17,20	18,50	19,10	20,00	23,90	25,00	30,00